

## CONTACT US

---



 Fax: (+86)0755-84737145

 Tex: (+86)130 0887 9993

 Email: [info@basengroup.com](mailto:info@basengroup.com)

 Website: [www.basenpower.com](http://www.basenpower.com)

 Shenzhen Basen Technology Co., Ltd.

 Add: Room 303, Building 3, 1980 Culture and Technology Industrial Park,  
Donghuan Road, Longhua District, Shenzhen



User Manual

---

**12V/24V**  
**Rechargeable Battery**  
**Lithium Iron Phosphate(LiFePO4)**

# YOUR RELIABLE POWER



## TABLE CONTENTS

Product Information	01
Installation Instructions	03
Charging Instructions	03
Discharge Instructions	04
Series and Parallel Connection Instructions	05
Warning and Attention	06
Storage and Transportation	07
Troubleshooting	08
Operation of Bluetooth	09
FAQ	11

# PRODUCT INFORMATION

The battery is designed and intended only for using in energy storage applications. Equipped with JBD battery management system (BMS), it can manage and monitor the performance of the battery during charging and discharging to ensure the safety and optimization of the battery. Common applications include utility trucks, emergency vehicles, RVs, yachts, golf carts, solar street lighting, UPS, emergency lighting, alarm systems and photovoltaic energy storage.

Specification														
Model	BG-12100	BG-12120	BG-12160	BG-12200	BG-12230	BG-12300	BG-12460	BG-24100	BG-24200	BG-24230				
Nominal Voltage	12.8V													
Capacity	100Ah	120Ah	160Ah	200Ah	230Ah	300Ah	460Ah	100Ah	200Ah	230Ah	25.6V			
Cycle times	4000(DoD 80%, 25°C)			5000(DoD 80%, 25°C)									4000(DoD 80%, 25°C)	5000(DoD 80%, 25°C)
Discharge														
Max. Continue Discharge Current	100A	100A	150A	100A	150A	200A	200A	100A	100A	100A	200A	200A		
Discharge Cut-off voltage	10.8V													
Operation Temperature														
Charge Temperature	0°C-55°C													
Discharge Temperature	-20°C-60°C													
Storage Temperature	0°C-45°C													
Protection Class	IP65													
Charging														
Charging Method	CC-CV													
Cut-off Charging Voltage	14.6V													
Max. Charging Current	100A	100A	150A	100A	150A	200A	200A	100A	100A	100A	200A	200A		
Other														
Terminals	M8(Threaded-hole)													
Size(mm)	260*168*210	339*185*218	330*172*220	384*194*255	384*204*268	384*194*255	522*268*218	522*242*218	522*269*220	522*268*218	522*268*218	522*268*218		
Weight	12kg	12kg	17kg	24kg	25kg	30kg	41kg	24kg	41kg	41kg	41kg	41kg		
Feature	2-5A active balance(optional) / Heating Function(optional)													

## Installation Instructions

- When replacing various deep cycle applications, please ensure the battery capacity is not less than the original lead-acid battery
- Please check the "Charging Instructions" before installation
- When connecting in series or in parallel, please ensure that the capacity and voltage of each battery are consistent (see "SERIES AND PARALLEL CONNECTION INSTRUCTIONS")
- Please check the battery to ensure the terminals are clean and rust-free, the screws are clean and free of foreign objects
- Please ensure that the screws on the terminals are fixed/tightened to the maximum to avoid loosening during operation. Make sure the washers are not placed between conductive connectors
- Please ensure that the cable connecting to the battery terminals is rated for the Max Continuous Amperage

## Charging Instructions

- Please ensure the charging voltage is 14.6V (+/- .2V) to 12V battery, 29.2V(+/- .2V) to 24V battery when charging the battery
- The charging current must not exceed the maximum charging current indicated in the PRODUCT INFORMATION section of this User Manual
- The batteries used in series do not need to be disassembled for separate charging. Also ensure that the individual batteries are fully charged before connecting in series (For more details refer to "SERIES AND PARALLEL CONNECTION INSTRUCTIONS")
- Please charge at an ambient temperature of 32°F to 131°F (0°C to 55°C). Charging below 32°F or above 131°F may cause irreversible damage to the battery or pose a safety risk
- Do not leave the battery charger connected to maintain or store the battery unless specifically programmed for 3-stage LiFePO4 battery charger. Leave the charger unattended at your own risk

- To charge a battery with a solar charging system, make sure the charging voltage is <14.6V(+/- 0.2V) to 12V battery/29.2V(+/- 0.2V) to 24V battery. If charging the 12V battery in a series, please ensure the charging voltage is <14.6V times the series number(e.g. The charging voltage for a 4 Series Battery should be <58.4V, and the charging current must follow the instruction outlined in "Charging Instructions")

## Discharge Instructions

- Please do not exceed the maximum discharge current listed in the table under the "PRODUCT INFORMATION" section
- The maximum continuous power should not exceed "Volt\*Capacity" W (i.e. In 12.8V100Ah, the maximum continuous load should not exceed 1280W)
- Do not mix a new battery with a used battery in the same configuration

## RECOMMENDED CHARGING/DISCHARGE SETTING

Model	12V LiFePO4 Battery	24V LiFePO4 Battery
Charging Limit Voltage	14.6V	29.2V
Equalizer Charging Voltage	14V	28V
Floating Charging Voltage	13.8V	27.6V
Balancing Voltage	<13.2V	<26.4V
Discharge Cut-off Voltage	10.8V	21.6V
Low voltage of Recover	11.8V	23.6V
Short Circuit Protection	250μs	250μs

# SERIES AND PARALLEL CONNECTION INSTRUCTIONS

Model	Threading	Torque	Recommended Wire Gauge	Length
12V100Ah	M8	10 Nm	4AWG	30~40cm /12~16int
12V120Ah	M8	10 Nm	4AWG	
12V160Ah	M8	10 Nm	4AWG	
12V200Ah	M8	10 Nm	4AWG	
12V230Ah	M8	10 Nm	2AWG/4AWG	
12V300Ah	M8	10 Nm	2AWG/4AWG	
12V460Ah	M8	10 Nm	2AWG/4AWG	
24V100Ah	M8	10 Nm	4AWG	
24V200Ah	M8	10 Nm	2AWG/4AWG	
24V230Ah	M8	10 Nm	2AWG/4AWG	

- To tighten bolts, use the correct tightening torque, as shown in the table above, and use insulated tools corresponding to the size of the nuts
- 12V100Ah Battery supports This battery supports 4 sets of batteries connected in parallel. For example, four 12V 100AH batteries can be connected in parallel to obtain a 12V 400AH battery, and if connected in series, a 48V100AH battery can be obtained. In the state of parallel connection, the length and gauge of the positive and negative power wiring need to be exactly the same.

P.S: Please contact BASEN for the series-parallel connection limitations of different models.

## Wiring Diagram for Batteries in Series

Lithium Batteries in Series

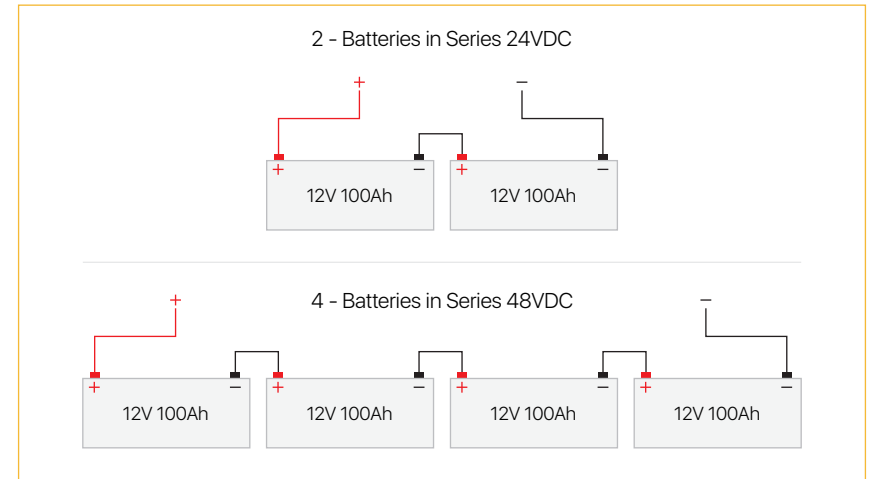

## Wiring Diagram for Batteries in Parallel

Lithium Batteries in Parallel

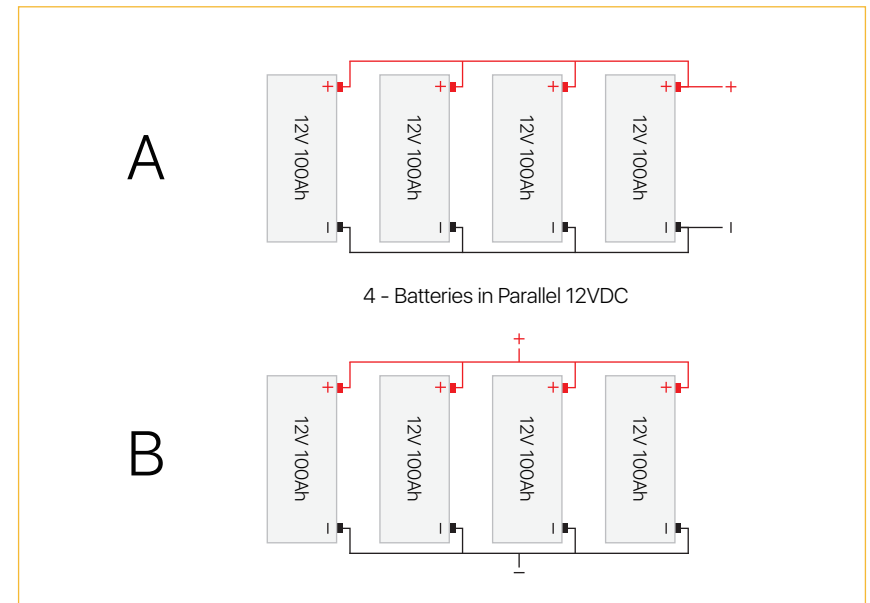

Note: parallel wiring for the positive and negative must be the same gauge and length

## Warning and Attention

- Do not reverse the positive and negative of the battery
- Do not touch or store the electrodes of the battery with unnecessary wires or other metal materials to avoid short circuit
- Do not puncture, impact, drop, or step on the battery
- Do not disassemble the battery or modify the outer casing
- Do not expose the battery to the sun since this may cause overheating, fire, or failure of the battery
- Do not put the battery in a fire or heat the battery. Do not store the battery in a high temperature environment
- Do not put the battery into water or expose it to rain for a long period of time. The battery should be stored in a cool and dry environment
- If you detect any abnormal smell or noise while charging or discharging, remove the battery immediately and contact the dealer
- When the battery is operated in the temperature range of 32°F to 122°F (0°C to 50°C) the capacity may decrease, but this does not mean that the battery is damaged

## Storage and Transportation

Item		Criteria
Storage temperature	<1 month	32°F to 113°F (0°C to 45°C)
	<3 months	32°F to 104°F (0°C to 40°C)
	>3 months	32°F to 86°F (0°C to 30°C)
Relative Humidity		<75% RH
SOC		40%~60%

- To ensure longer battery lifespan, please recharge the battery every 3-6 months

- Please ensure the battery terminals and screw holes are clean and securely connected
- If the load is in an unused situation for a long time, disconnect the battery from the load to prevent the battery from leakage and causing the battery to be over-discharged
- Insulation and shockproof materials should be used for the outer packaging to avoid sudden collisions and squeezing during transportation

## Troubleshooting

NO.	Symptom	Possible Causes	Corrective Actions
1	No DC Output	Battery being protected by BMS	Check the circuits/working environment and confirm the load power to ensure battery is being charged/discharged within Max charging/discharging current stated in the Specifications
		BMS failed	Replace the battery
2	Battery working time is too short	The charging voltage is too low and battery cannot be fully charged	Adjust the charging voltage 14.4V(12V batt) 28.8V(24V batt)
		The load voltage is too high and the battery cannot be fully discharged	Reduce the load voltage or replace the battery with a larger capacity one
		Over temperature	Lower down ambient temperature
3	Battery heat up	Battery capacity becomes lower	Replace the battery
		Over current	Reduce the load power
		Over temperature	Working within the operating temperature
4	Spark occurs on cable terminals	Initial connect to capacitive or inductive load	No action is required
		Power supply short circuit	Check the cause of the short circuit and disconnect it

# Operation of Bluetooth

BASENGREEN 12V/24V battery pack is equipped with a Bluetooth function, supports APP monitoring battery statuses. All information available in the battery, such as the state of charge, voltage, operating current, temperature, and other operating information are transmitted in real-time via the Bluetooth transmitter. The parameters can be made visible with the BASENGREEN App.

**Download: Android: "BASENGREEN" in Play Store**

**iOS: "BASENGREEN" in Apple Store**

a. For Android users, please visit the Google Play Store and search for 'BASENGREEN'. For iOS users, go to the Apple Store and look up 'BASENGREEN'.

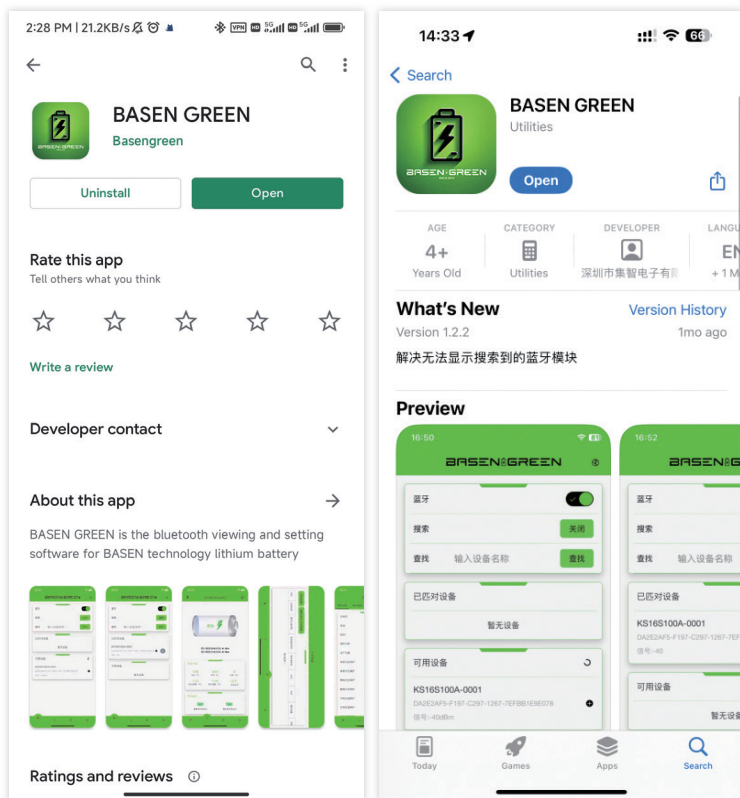

b. Turn on Bluetooth and search for the corresponding product's Bluetooth code

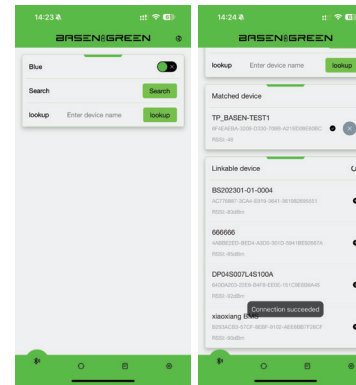

**NOTE:**

- 1.If you selected a battery to connect to and the app doesn't confirm the connection, it might be someone else is already connected to the battery. Only one device connects to the battery at the same time.
- 2.The Bluetooth app supports status monitoring only.

c. Menu



**Bluetooth list:** Check the Device list and connect it.

**Homepage:** Check the status of battery-SOC, Volt, Current, Temperature, etc.

**Historical Data:** Not available

**Setting:** Base Message: Check the pack voltage, current, cycle time, etc.

**Cell Voltage:** Check the cells voltage.

**Language:** English/Chinese switching.

**Fault Data:** Not available

**System Parameter:** Not available

# FAQ

## 1. Why choose BASEN

A: -----

- Worry-free after-sales service with a 5-year battery warranty
- Ready stock in US/EU warehouses, faster lead & delivery time.
- All required professional certificates: CE/ROHS.
- Automotive-grade battery cells with the most competitive price

## 2. What battery do I need for different applications?

A: To choose a proper battery for your application, you need to refer to the required wattage of power draw & running time of the application, and choose a suitable battery model accordingly. Please feel free to email us to chat with us or consult us at [info@basengroup.com](mailto:info@basengroup.com) and we will help recommend the proper battery for your application

## 3. Compared with lead-acid batteries, what are the advantages of LiFePO4 batteries?

A: -----

- DEPTH OF DISCHARGE (DOD): About 85% of the energy capacity can be drained before they need to be charged 95% EFFICIENCY over 950W can be used for every 1000w of solar power absorbed by batteries.
- HIGHER ENERGY DENSITY OR CAPACITY Store a higher amount of energy for the same size
- LESS COST: while lead-acid batteries may ostensibly be more affordable, the long-lasting life cycles and effectiveness of LiFePO4 batteries offset that costs.
- 4000+CYCLES LIFESPAN: BASEN LiFePO4 batteries can be for 4000+ cycles while lead-acid batteries typically only have about 200-500 charge cycles

## 4. If my package has been damaged or defective, what should I do?

A: We have analyzed and tested every battery before they're ready to be sold. However, sometimes the battery may be damaged or defective due to incorrect handling in transit or delivery. If unfortunately the battery you receive is damaged or defective, please don't worry and feel free to contact us at any time. We will always try our best to provide you with the best solution

## 5. Does your battery have a low-temperature cut-off function?

A: Yes, all of the 12V/24V battery pack has low-temperature protection function. But if you need the battery packs to work under 0 C , please contact BASEN for the optional self-heating function.

## 6. How to choose the right battery chargers?

A: Before choosing a charger for your BASEN LiFePO4 battery, you can refer to the following info: Dedicated LiFePO4 battery charger /support LiFePO4 charging mode: DC charging voltage and DC charging current match the requirement that we list in the user manual.

## 7. Are the batteries waterproof?

A: Our batteries are IP65 rated. Because the battery terminal's positive and negative electrodes are charged. So even if the battery is sealed, waterproof and dustproof grade to IP65, the battery is not allowed to be used in water. Therefore, our batteries require special battery box protection

## 3 WAYS TO RECHARGE THE BATTERY



12V(14.6V)10A  
Lifepo4 Battery  
Charger: 10 hrs



Solar Panels  
(Recommend  $\geq 300W$ )  
within 4.26 hrs



Generator  
(Add a 20A DC  
to Charger): 5 hrs